

# Common Control Panel for Air Compressor Systems

## Features

- \* To Implement a SCADA control system for a CCP.
- \* To Monitor the Compressor utilization, Switch OFF and ON the compressor based on plant requirement.
- \* Time synchronization using Global positioning system.
- \* To Communicate all information to DCS through Ethernet TCP/IP.
- \* To Capture vibration Monitoring system parameters and communicate to DCS.

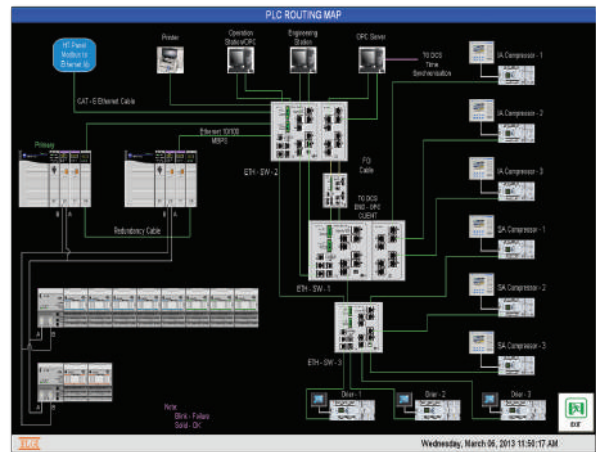

## Specifications

PLC	Control Logix L61 redundant system (1756-L61, 230VAC, 2MB, Remote I/O, EtherNet IP, ControlNet, DeviceNet)
Input	Flex Digital 96 Nos Flex Analog 12 Nos
Outputs	Flex Digital 40 Nos
Networking	Ethernet distributed IO modules network Fibre Optic communication to transfer data to DCS
Communication	Ethernet TCP/IP
Panels	Rittal panel with IP 55
Compliance	IEC UL/CSA
SCADA	Factory Talk - SE
Project Implemented	An Indian state-owned integrated power plant equipment manufacturer
Duration of Project	20 days
Scope of our Supply	Design, Development, manufacture of Panels and SCADA development and implementation.

**Applied Control Equipment Systems**

S.F.No.415, Codissia Road, Opp.Geethanjali School,  
Peelamedu, Coimbatore - 641 004.

Contact : +91 948 755 3082

E-Mail : appliedcontrol@gmail.com